

SUPERNOVA TRIMLESS 9583 ED5

DEEL
PARTIE
TEIL
PART
PARTE
PARTE **A**

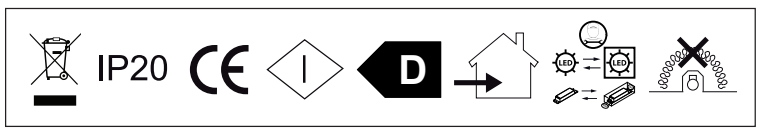
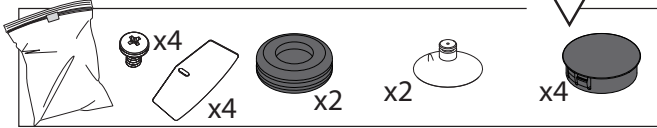
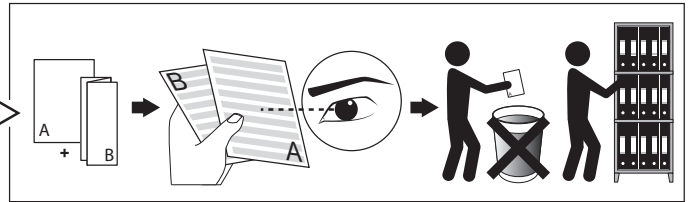
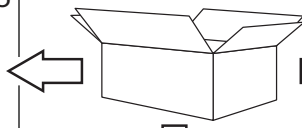
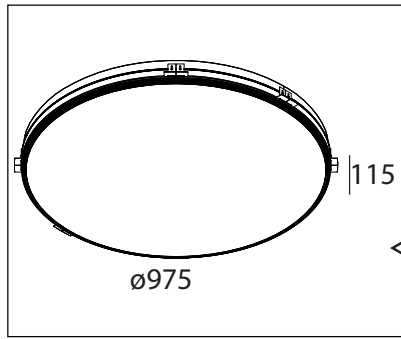

Warm White 0% Cold White 100%	Warm White 50% Cold White 50%	Warm White 100% Cold White 0%	<p>ADRESS "0" (Power) = 0% ↔ 100%</p> <p>ADRESS "1" (Color) = 2700K ↔ 5700K</p> <p>Methode DT6 (Device Type 6)</p>	<p>SUPERNOVA TRIMLESS 9583 ED5 Ø985mm</p>
----------------------------------	----------------------------------	----------------------------------	---	--

IP20
 Beschermtd tegen vaste voorwerpen die groter zijn dan 12 mm
 Protégé contre les objets solides de plus de 12 mm
 Geschützt gegen Festkörper größer als 12 mm
 Protected against solid objects greater than 12 mm
 Protegido contra objetos sólidos superiores a 12 mm
 Protetto contro oggetti solidi più grandi di 12 mm

Voorzien van aardingsaansluiting
 Avec mise à la terre
 Ausgerüst tet mit Erdungsanschluss
 Provided with grounding
 Con la toma de tierra
 Con presa a terra

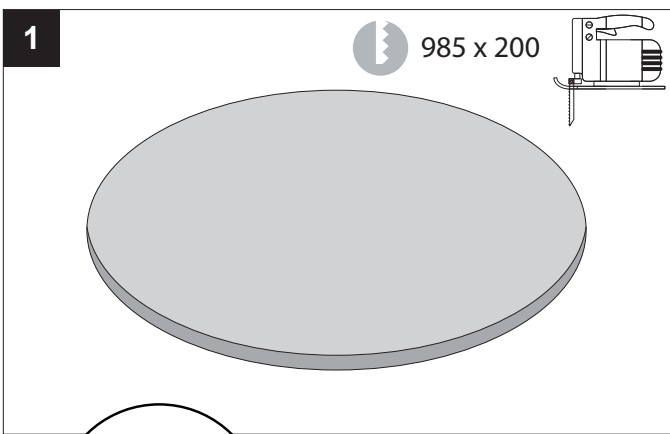

Toestel niet geschikt om te worden afgedekt met thermische isolatie.
 Luminaires non appropriées pour recouvrement d'un matériau isolant thermique.
 Das Gerät/Die Leuchte darf nicht abgedeckt werden mit thermischer Isolation.
 Luminaire not suitable for covering with insulating material.
 Luminaria no apta para cubrir con material aislante.
 Apparecchio non adatto per essere coperto da materiale isolante.

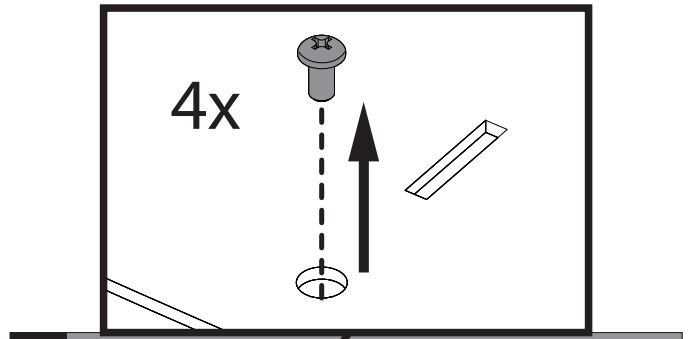
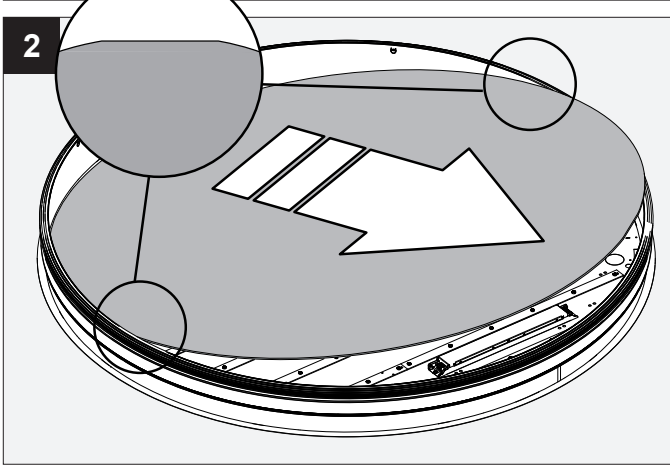

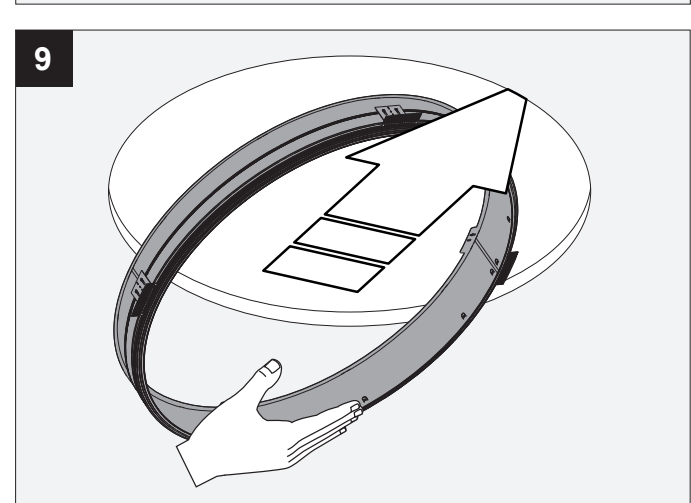
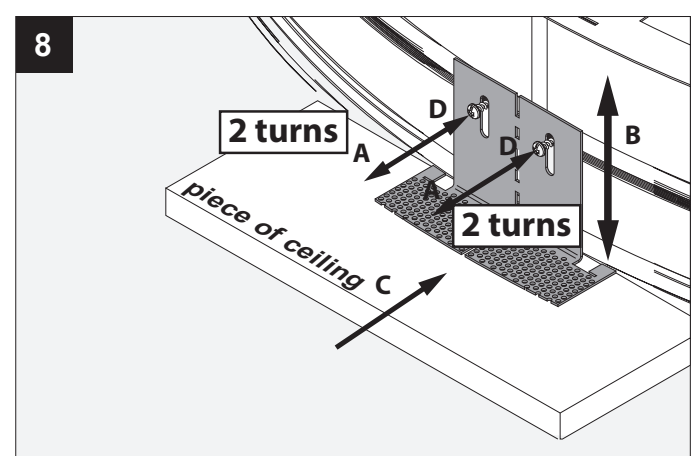
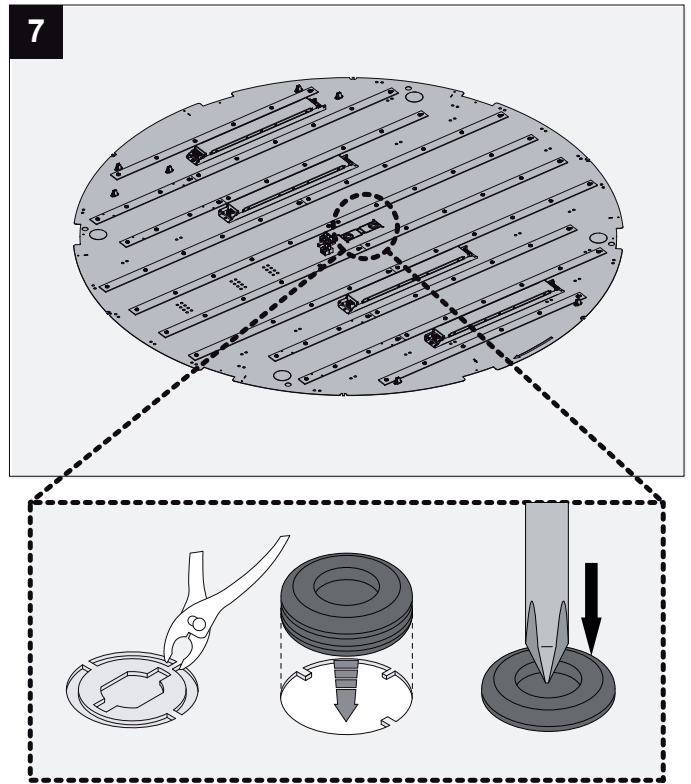
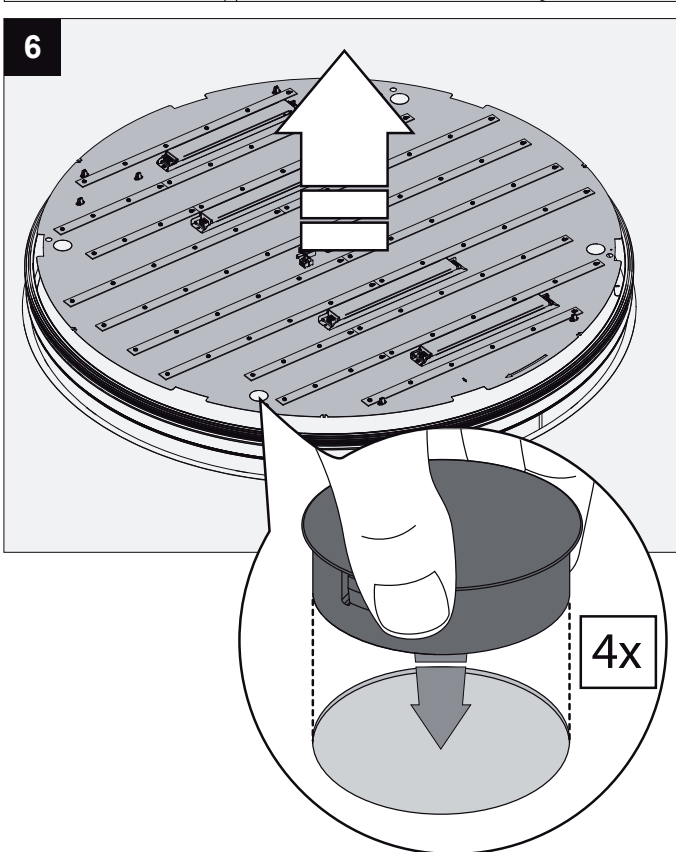
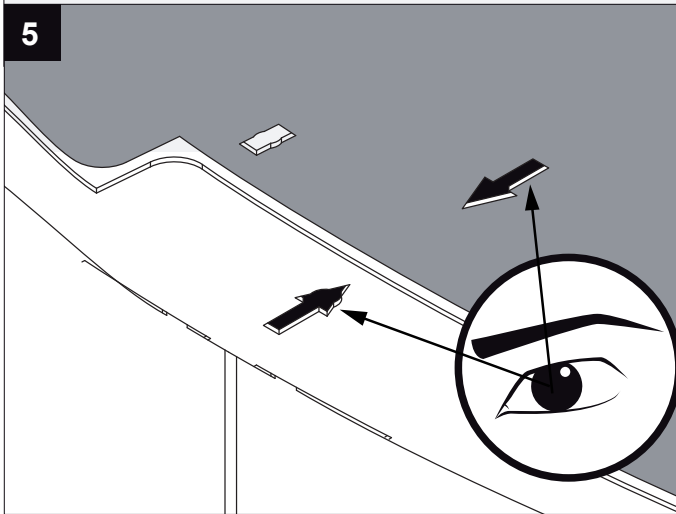
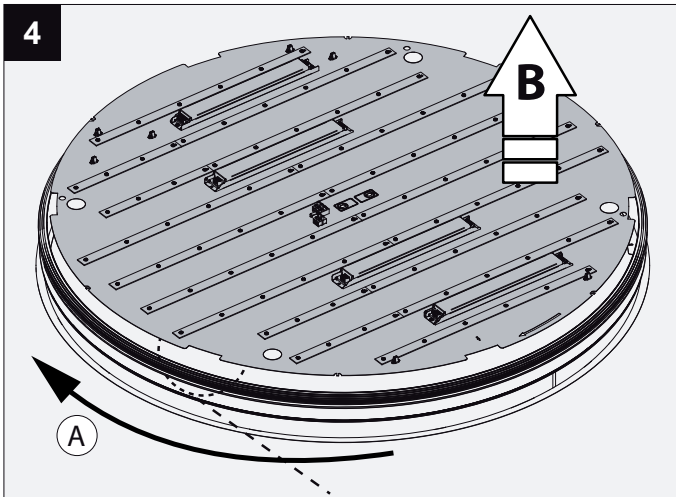

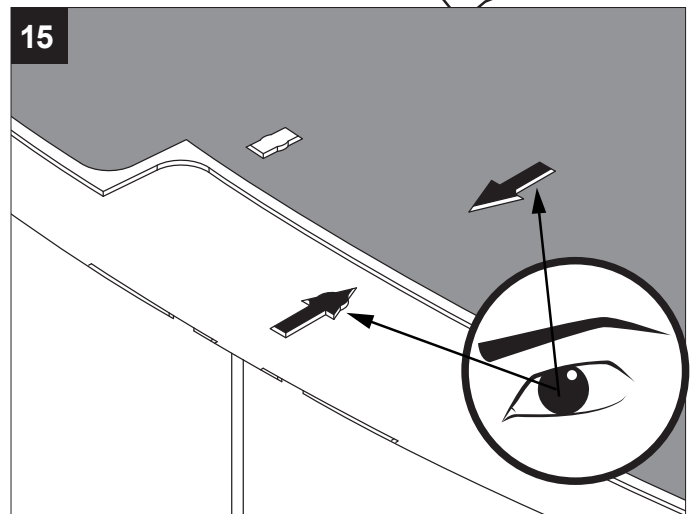
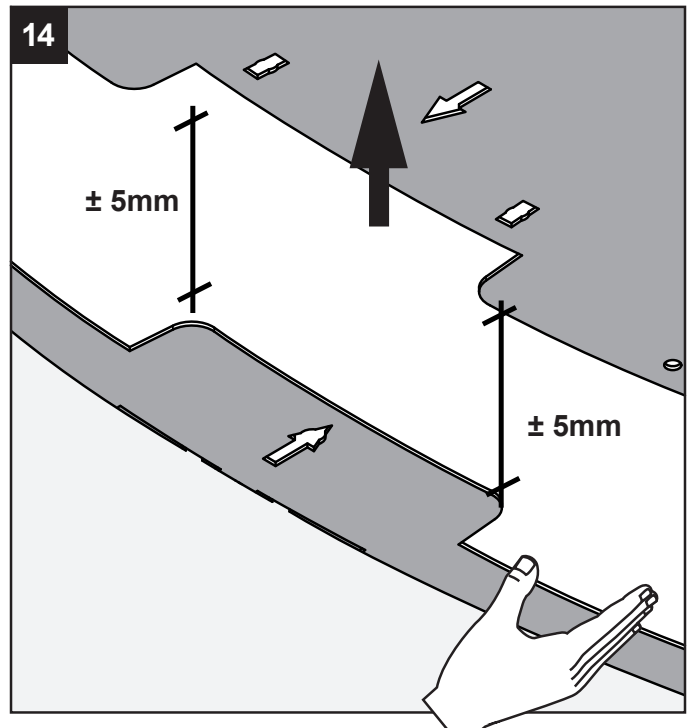
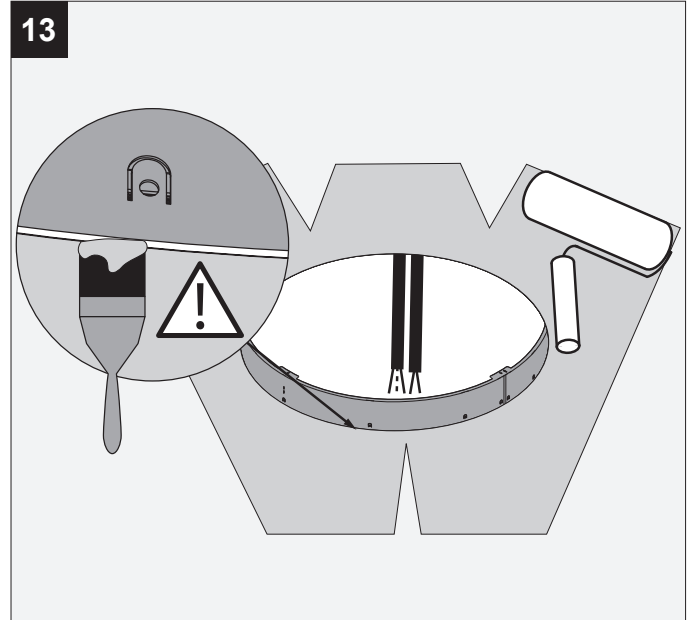
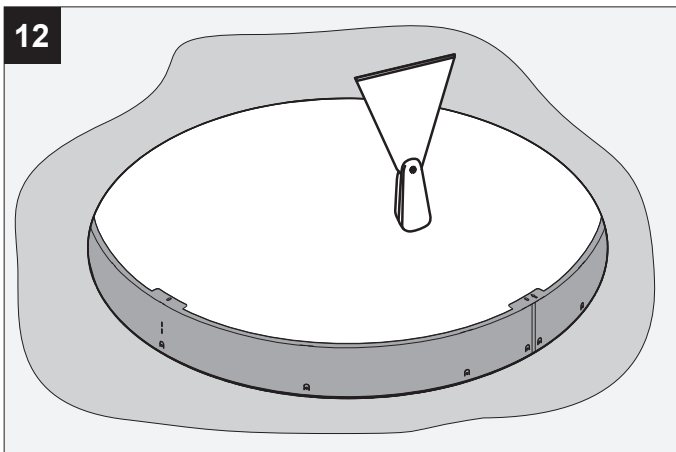
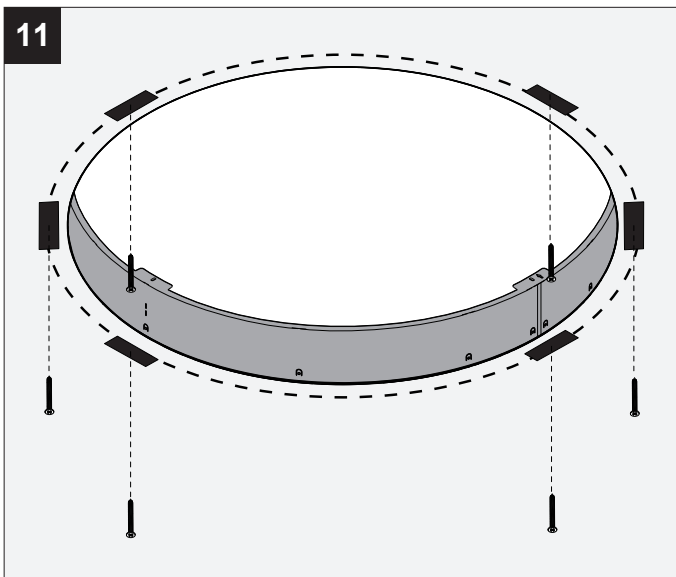
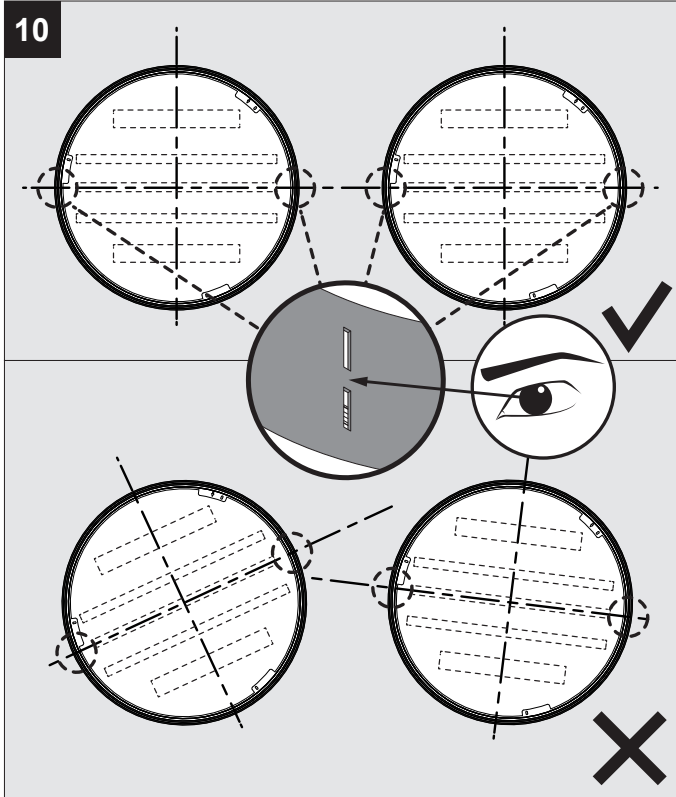

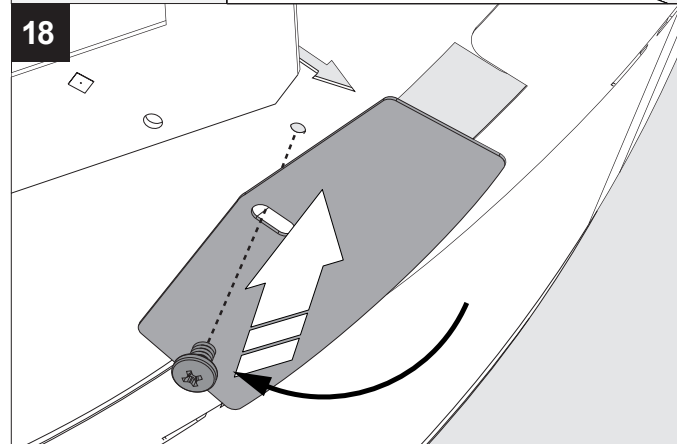
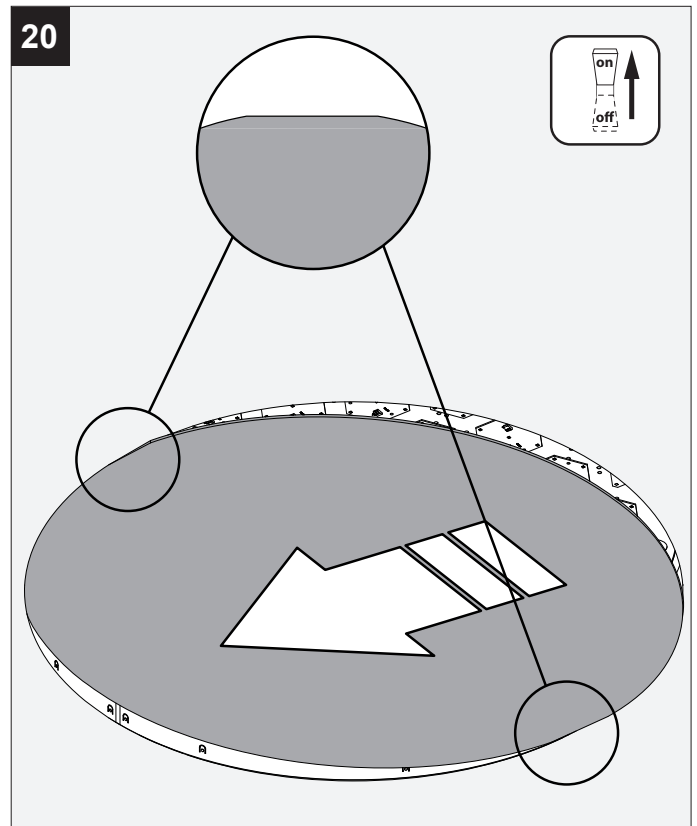
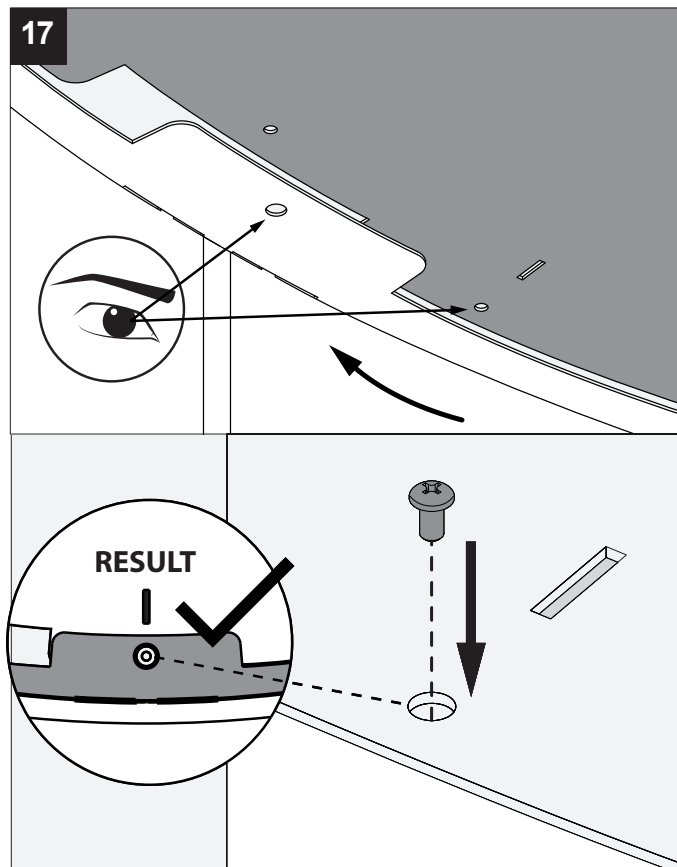
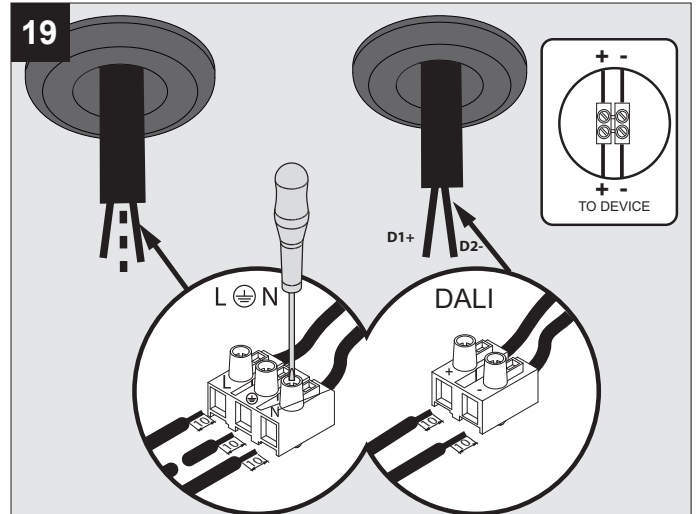
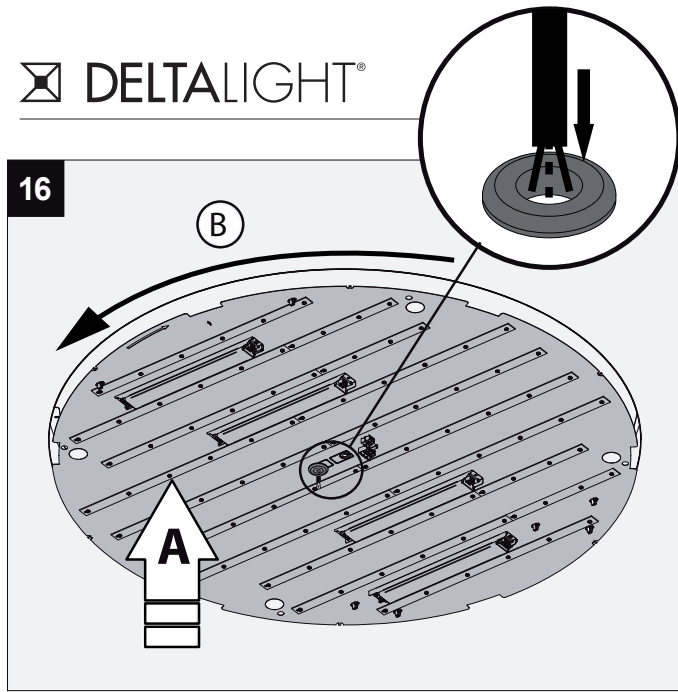

De verlichtingsbron van dit verlichtingstoestel zal enkel door de fabrikant of door de fabrikant aangestelde installateur vervangen worden.

La source lumière de cet appareil ne sera remplacée que par l'entrepre-
se ou par un agent reconnu.

Das enthaltene Leuchtmittel sollte nur durch entsprechendes Fachper-
sonal ersetzt werden.

The light source contained in this luminaire shall only be replaced by
the manufacturer or his service agent.

La fuente de iluminación que tiene esta luminaria sólo puede reempla-
zarse por el fabricante o por un instalador autorizado.

La sorgente luminosa incorporata in questo apparecchio può essere
sostituita solo dal produt tore, da un suo centro assistenza oppure da
una persona in possesso della necessaria abilitazione.

HOW TO PLACE THE LENS IN THE SUPERNOVA TRIMLESS?

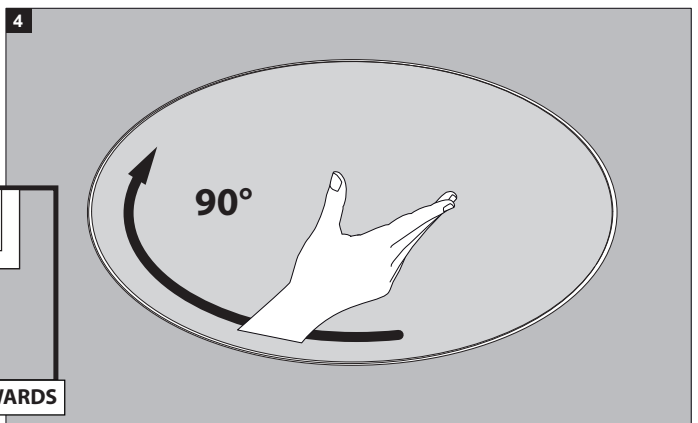
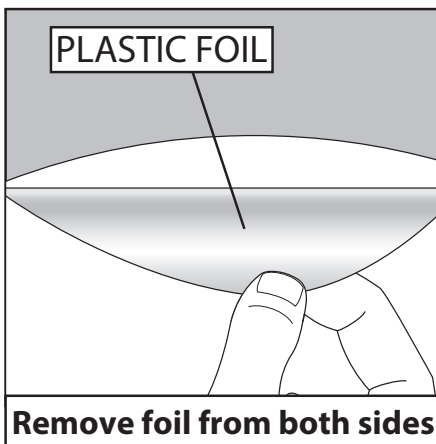
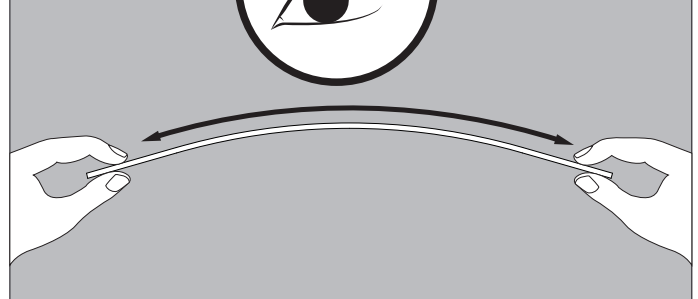
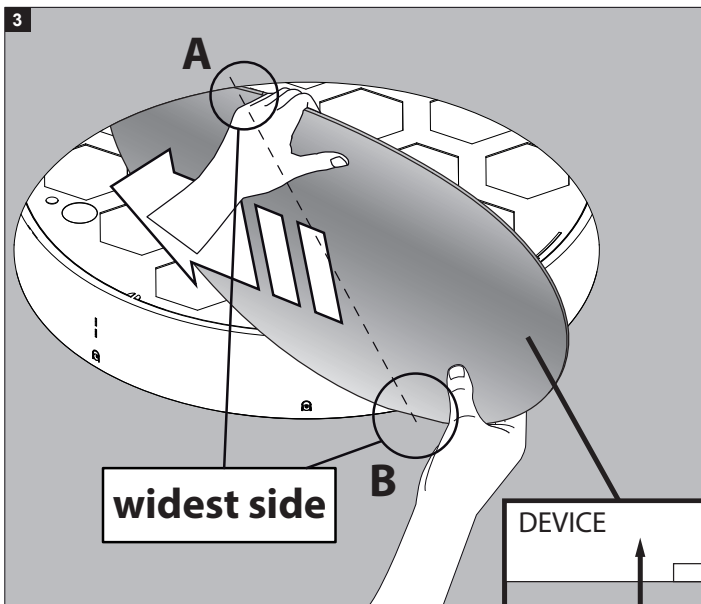
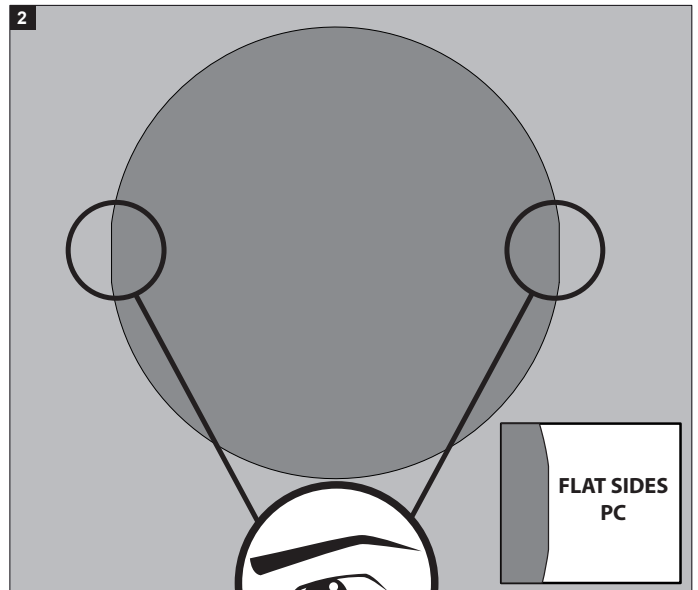
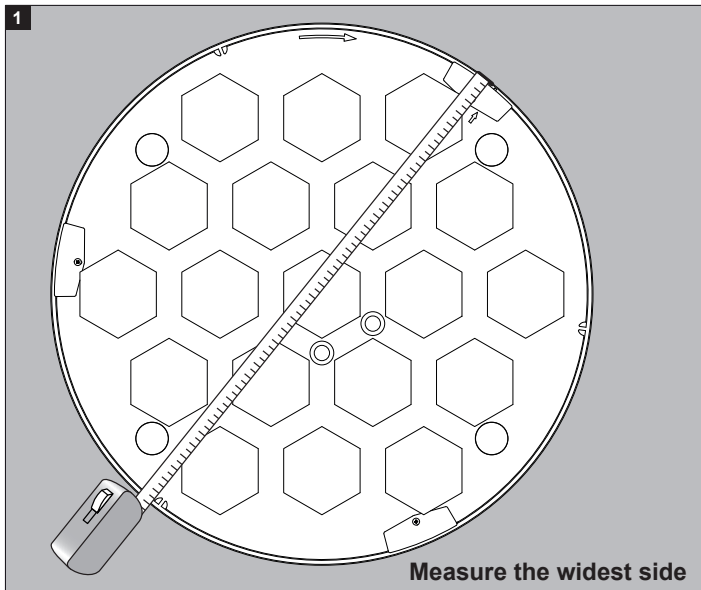

D This product contains a light source of energy efficiency class D
 本产品包含能效等级为 D 的光源
 Этот артикул содержит источник света с энергоэффективностью класса D
 يحتوي هذا المنتج على مصدر ضوء ذو كفاءة الطاقة D
 Dit product bevat een verlichtingsbron van energie-efficiëntieklasse D
 Ce produit contient une source d'éclairage de classe d'efficacité énergétique D
 Dieses Produkt enthält eine Lichtquelle der Energieeffizienzklasse D
 Este producto contiene una fuente de iluminación de clase de eficiencia energética D
 Questo prodotto contiene una fonte di illuminazione in classe di efficienza energetica D

Replaceable (LED only) light source and control gear by a professional
 (仅针对LED) 光源及其控制设备只能由专业人员更换
 (для СВЕТОДИОДНЫХ светильников) замена источника света и блока питания может быть произведена только квалифицированным специалистом
 مصدر الضوء (إيد فقط) و معدات التحكم قابلين للتغيير بإشراف الفني المتخصص
 Verlichtingsbron (enkel LED) en voorschakelapparaat kan enkel vervangen worden door een professional
 La source d'éclairage (uniquement LED) et le ballast ne peut être remplacé que par un professionnel
 Die Lichtquelle (nur LED) und Vorschaltgerät kann nur von einem Fachmann ausgetauscht werden
 La fuente de iluminación (solo LED) solo puede ser reemplazada por un profesional
 La sorgente luminosa (LED) e l'alimentatore possono essere sostituiti solo da un professionista.